

# Owner's manual

## ELECTRONIC CONTROL SYSTEM

# Power A Mark II™

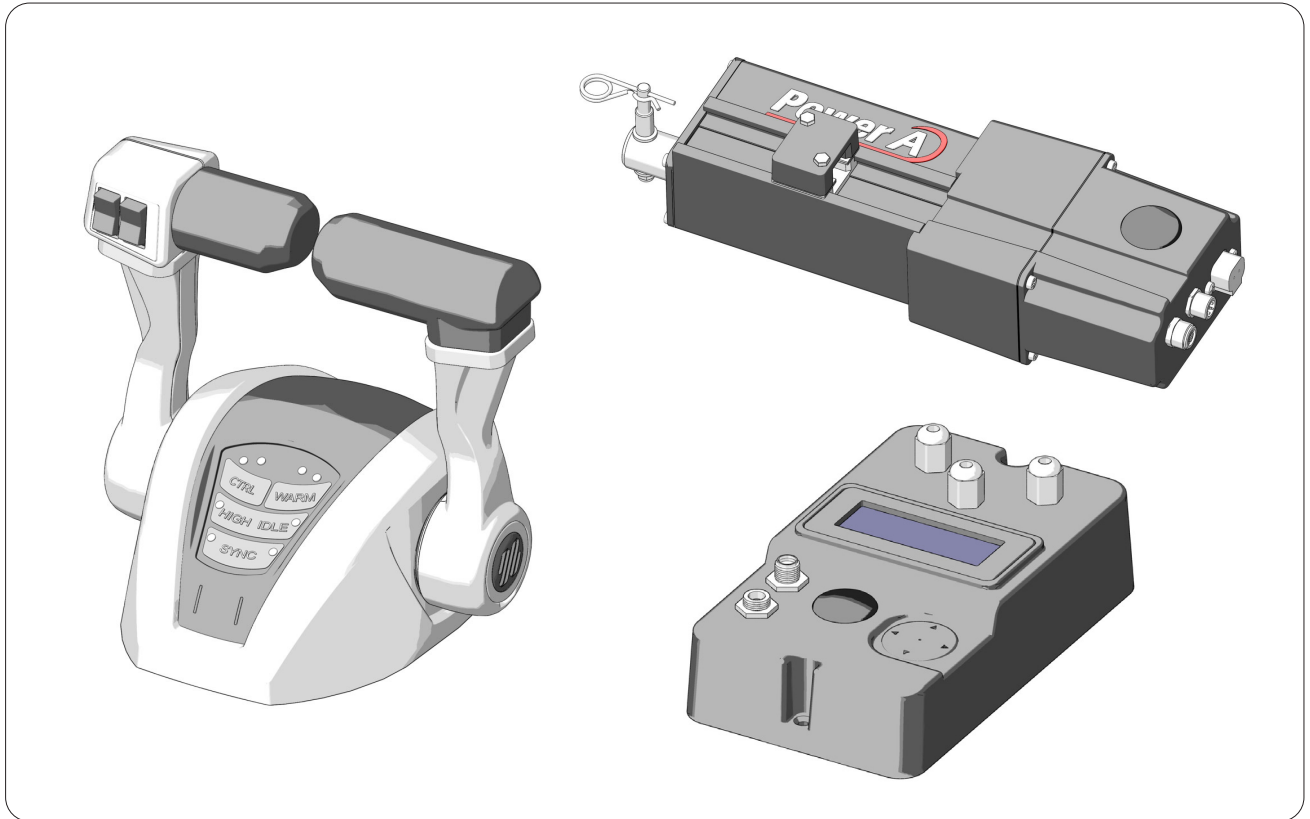

ENGLISH

CE

 **ULTRAFLEX**





Dear Customer,

We would like to thank you for choosing an **ULTRAFLEX** product.

**ULTRAFLEX** has been a leader in steering systems for pleasure and professional boats for many years. **ULTRAFLEX** production is since ever synonymous of reliability and safety.

All **ULTRAFLEX** products are designed and manufactured to ensure the best performance. To ensure your safety and to maintain a high quality level, **ULTRAFLEX** products are guaranteed only if they are used with original spare parts.

**ULTRAFLEX** and **UFLEX** Quality Management Systems are certified by the Det Norske Veritas - Germanischer Lloyd (DNV-GL), in conformity with the UNI EN ISO 9001:2015 rule.

The quality management system involves all the company resources and processes starting from the design, in order to:

- ensure product quality to the customer;
- maintain and improve the quality standards constantly;
- pursue a continuous process improvement to meet the market needs and to increase the customer satisfaction

**ULTRAFLEX** Environmental Management System is certified by the Det Norske Veritas - Germanischer Lloyd (DNV-GL), in conformity with the UNI EN ISO 14001:2015 rule.

Products for pleasure boats are constantly tested to check their conformity with the 2013/53/EU.



"**ULTRAFLEX** has over 80 years of experience in the marine industry and is a world leader in the production of mechanical, hydraulic and electronic steering systems, control boxes and steering wheels for any kind of pleasure, fishing or commercial boats.

The key factors which explain the increasing success of our products all over the world are the reliability of our products and the before and after sale service, the quality of the company organization and of the human resources and the continuous spending in research and development".

**ULTRAFLEX S.p.A.**

16015 Casella (Genova) Italia - Via Crose, 2

# TABLE OF CONTENTS

DOCUMENT REVISIONS.....	4
MANUAL USE AND SYMBOLS USED.....	5
INFORMATIVE LETTER.....	6
WARRANTY.....	6

## SECTION 1 - PRODUCT DESCRIPTION

1 PRODUCT DESCRIPTION.....	7
----------------------------	---

## SECTION 2 - USE

2.1 CONTROL DESCRIPTION.....	10
2.2 OPERATION OF THE CONTROL STATION LEVERS.....	12
2.3 SYSTEM START.....	13
2.3.1 SYSTEM POWER SUPPLY.....	13
2.3.2 PANEL KEY ENABLING.....	13
2.3.3 ENGINE SWITCHING ON.....	14
2.3.4 CONTROL ENABLING.....	14
2.3.5 MULTIPLE CONTROL STATIONS.....	15
2.4 USE MODES.....	16
2.4.1 WARM UP MODE.....	16
2.4.2 AUTOSYNC MODE.....	17
2.4.3 HIGH-IDLE MODE.....	18
2.4.4 SAIL MODE.....	19
2.4.5 TROLL MODE.....	20
2.4.6 DOCKING MODE.....	21
2.4.7 PANEL BRIGHTNESS ADJUSTMENT.....	22

## SECTION 3 - WARNINGS AND ALARMS

3.1 CONTROL STATION.....	24
3.2 V-THROTTLE, I-THROTTLE, PWM-THROTTLE, SAEJ-THROTTLE.....	26
3.3 SHIFT UNIT.....	27
3.4 MECHANICAL ACTUATOR USED AS THROTTLE.....	29
3.5 MECHANICAL ACTUATOR USED AS SHIFT.....	31
3.6 CONTROL UNIT.....	33

## SECTION 4 - SAFETY WARNINGS

4.1 SAFETY STANDARDS DURING INSTALLATION AND USE.....	35
4.2 CLOTHING.....	35

## SECTION 5 - MAINTENANCE

5.1 ROUTINE MAINTENANCE.....	36
5.1.1 CLEANING.....	36
5.1.2 ONE MONTH AFTER PRODUCT INSTALLATION.....	36
5.1.3 EVERY THREE MONTHS.....	36
5.1.4 EVERY YEAR.....	36
5.2 EXTRAORDINARY MAINTENANCE.....	36

## SECTION 6 - DISMANTLING

6.1 DISMANTLING.....	37
----------------------	----

## ENCLOSURES





## DOCUMENT REVISIONS

Rev.	Date	Revision description
0	02/09/2011	First edition
1	25/03/2025	Addition: SAIL function

## MANUAL USE AND SYMBOLS USED

THE INSTALLATION AND MAINTENANCE MANUAL is the document accompanying the product from sale to replacement and discharge. The manual is an important part of the product itself. It is necessary to read carefully the manual, before ANY ACTIVITY involving the product, handling and unloading included.

In this manual the following symbols are used to ensure the user safety and to guarantee the correct product working.

 <b>DANGER</b>	➔	Immediate hazards which CAUSE severe personal injury or death.
 <b>WARNING</b>	➔	Denotes that a hazard exists which can result in injury or death if proper precautions are not taken.
 <b>CAUTION</b>	➔	Denotes a reminder of safety practices or directs attention to unsafe practices which could result in personal injury or damage to the craft or components or to the environment.
<b>NOTICE</b>	➔	Important information for the correct installation and for maintenance, that does not cause any damage.
	➔	The symbol aside indicates all the operations which must be carried out by qualified or skilled staff, in order to avoid hazards. We recommend training the staff in charge of the product installation and checking their knowledge.

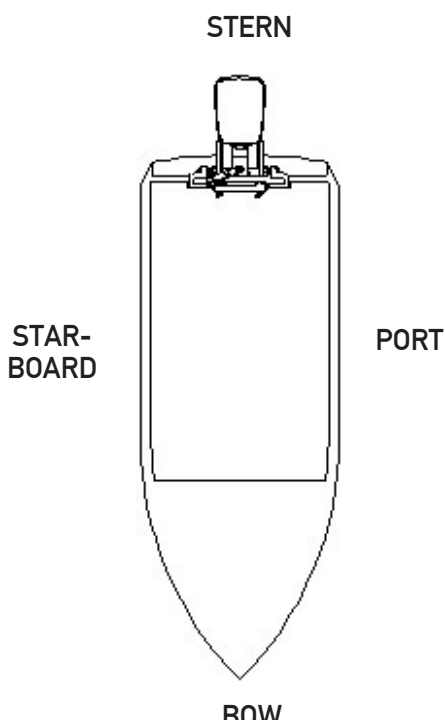

➔ The picture aside explains the meaning of some nautical words contained in this manual.

**LEGEND**

m.p.h. = miles per hour  
 km/h = kilometres per hour

10 m.p.h. = 8.69 knots  
 10 m.p.h. = 16.1 km/h  
 10 knots = 11.5 m.p.h.  
 10 knots = 18.5 km/h  
 10 km/h = 6.21 m.p.h.  
 10 km/h = 5.4 knots

ENGLISH

## INFORMATIVE LETTER

This installation and maintenance manual represents an important part of the product and must be available to the people in charge of its use and maintenance.

The user must know the content of this manual.

**ULTRAFLEX** declines all responsibility for possible mistakes in this manual due to printing errors.

Apart from the essential features of the described product, **ULTRAFLEX** reserves the right to make those modifications, such as descriptions, details and illustrations, that are considered to be suitable for its improvement, or for design or sales requirements, at any moment and without being obliged to update this publication.

ALL RIGHTS ARE RESERVED. Publishing rights, trademarks, part numbers and photographs of **ULTRAFLEX** products contained in this manual are **ULTRAFLEX** property.

Great care has been taken in collecting and checking the documentation contained in this manual to make it as complete and comprehensible as possible. Nothing contained in this manual can be interpreted as warranty either expressed or implied - including, not in a restricted way, the suitability warranty for any special purpose. Nothing contained in this manual can be interpreted as a modification or confirmation of the terms of any purchase contract.

### WARNING

To ensure the correct product and component operation, the product must be installed by qualified staff. In case of part damage or malfunction, please contact the qualified staff or our Technical Assistance Service.

### TECHNICAL SERVICE

#### **UFLEX S.r.l.**

Via Milite Ignoto,8A  
16012 Busalla (GE)-Italy  
Tel: +39.010.962.01  
Email: [service@ultraflexgroup.it](mailto:service@ultraflexgroup.it)  
[www.ultraflexgroup.it](http://www.ultraflexgroup.it)

#### North - South - Central America:

#### **UFLEX USA**

6442 Parkland Drive  
Sarasota, FL 34243  
Tel: +1.941.351.2628  
Email: [sales@uflexusa.com](mailto:sales@uflexusa.com)  
[www.uflexusa.com](http://www.uflexusa.com)

## WARRANTY

**ULTRAFLEX** guarantees that its products are well designed and free from manufacturing and material defects, for a period of two years from the date of manufacturing.

For the products which are installed and used on working or commercial boats the warranty is limited to one year from the date of manufacturing.

If during this period the product proves to be defective due to improper materials and/or manufacture, the manufacturer will repair or replace the defective parts free of charge.

Direct or indirect damage is not covered by this warranty. In particular the company is not responsible and this warranty will not cover the damage resulting from incorrect installation or use of the product (except for replacement or repair of defective parts according to the conditions and terms above).

This warranty does not cover the products installed on race boats or boats used in competitions.

The descriptions and illustrations contained in this manual should be used as general reference only.

For any further information please contact our Technical Assistance Service.

**ULTRAFLEX** steering system components are marked **CE** according to the Directive 2013/53/EU.

We remind you that only **CE** marked steering systems must be used on the boats marked **CE**.

We inform you that the **ULTRAFLEX** warranty is null if some **ULTRAFLEX** components are installed on a steering system together with products of other brands.

# 1 PRODUCT DESCRIPTION

The **Power A Mark II™** system is made up of a series of intelligent modules which communicate via a proprietary CAN bus. They altogether control the boat propulsion engines, and at the same time allow the adjustment of the boat attitude stabilizers.

The user can control the throttle and the shift of the boat engine by means of the control station, which will be equipped with one or two levers according to the number of engines on the boat.

The trims to control the attitude stabilizers can be located on the port lever (the only one in case of single-engine boats).

## STANDARD CONTROL STATION WITH STANDARD KEYPAD

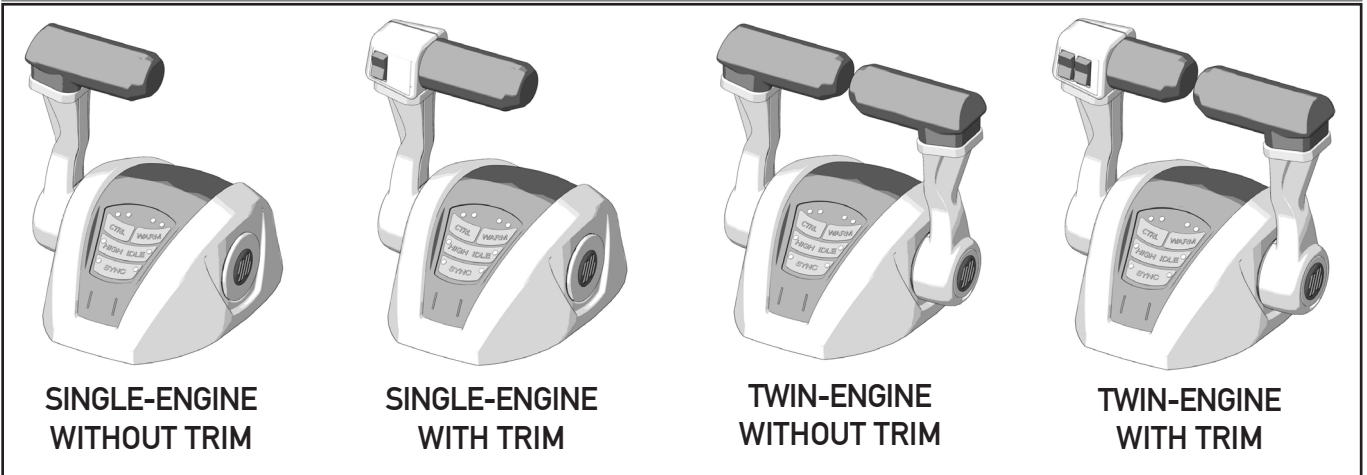

ENGLISH

## STANDARD CONTROL STATION WITH SAIL KEYPAD

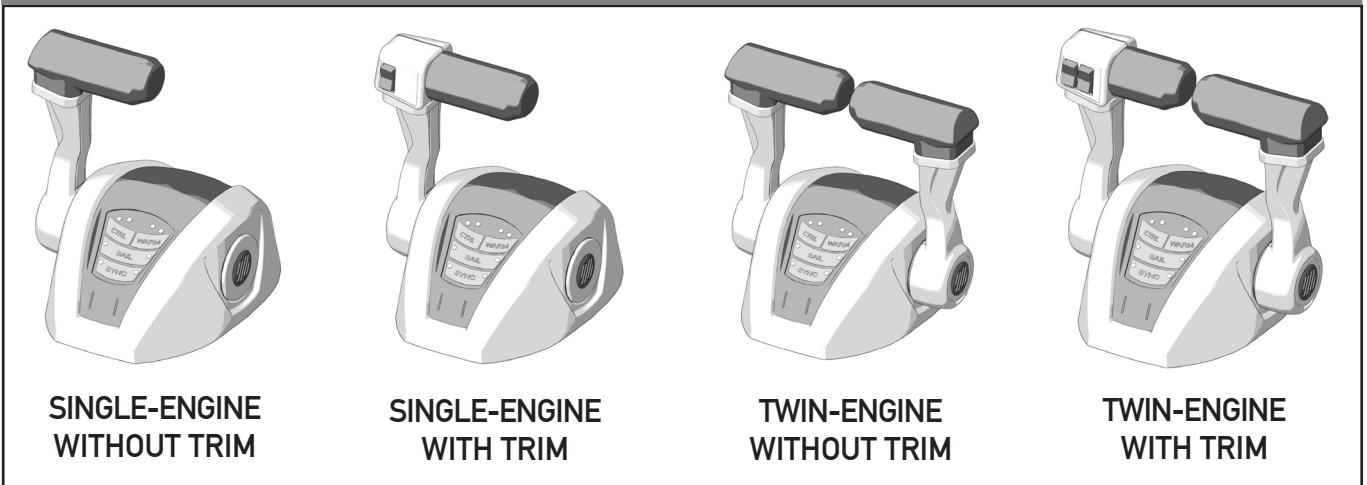

## COMPACT CONTROL STATION



SINGLE ENGINE WITH STANDARD KEYPAD



TWIN ENGINE WITH STANDARD KEYPAD



SINGLE ENGINE WITH SAIL KEYPAD



TWIN ENGINE WITH SAIL KEYPAD

ENGLISH

The boat can be equipped with maximum four control stations; the user will be allowed by the system to control the boat using only one station at a time.

The **PowerA Mark II™** system is always provided with a control unit used to carry out calibrations and diagnostic.

## CONTROL UNIT

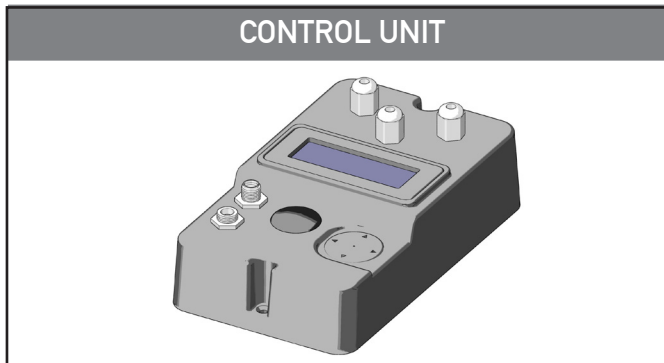

The other components vary according to the application: whenever a mechanical interface (it may be a throttle or a shift) must be controlled, a mechanical actuator has to be used.

## MECHANICAL ACTUATOR

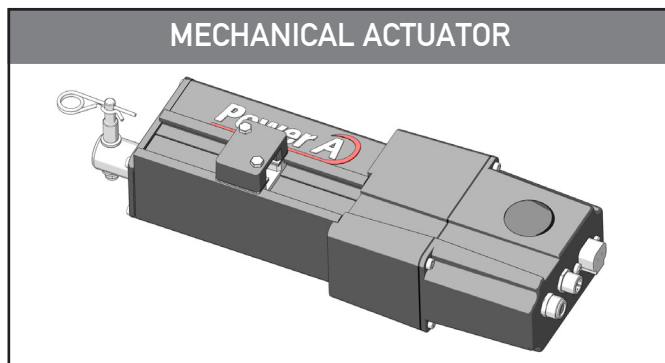



If the throttle is electronic, there will be an analogue or digital dedicated interface. Throttles with under-voltage analogue interface or PWM are provided with the V-throttle unit. Similarly, throttles with under-current analogue interface are provided with the I-throttle unit, which is externally identical to the V-throttle unit.



If the throttle is provided with a CAN bus digital interface a SAEJ-throttle or a NMEA-throttle unit must be used.



In case of electric shifts, a shift unit allowing the gear solenoid control is used.

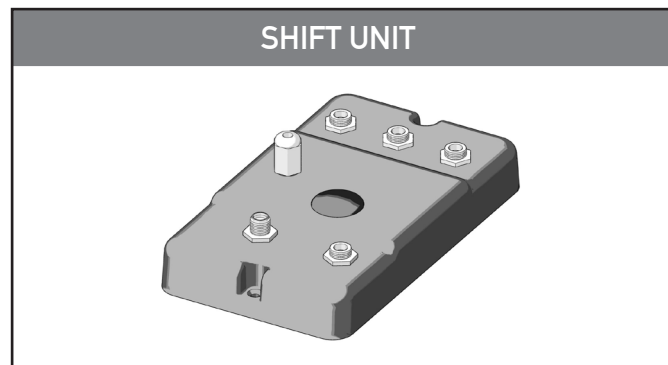

The power unit has the function of supplying the system devices (shift unit and mechanical actuator) with power.

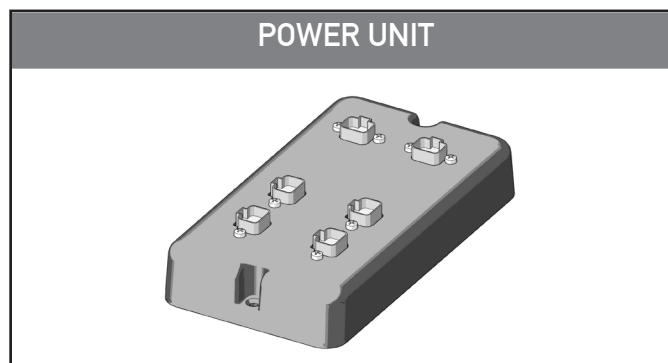

## 2 USE

### 2.1 Control description

The pictures below show an enlargement of the user interface located on the control stations.

#### STANDARD VERSION

The interface is the same for all versions.

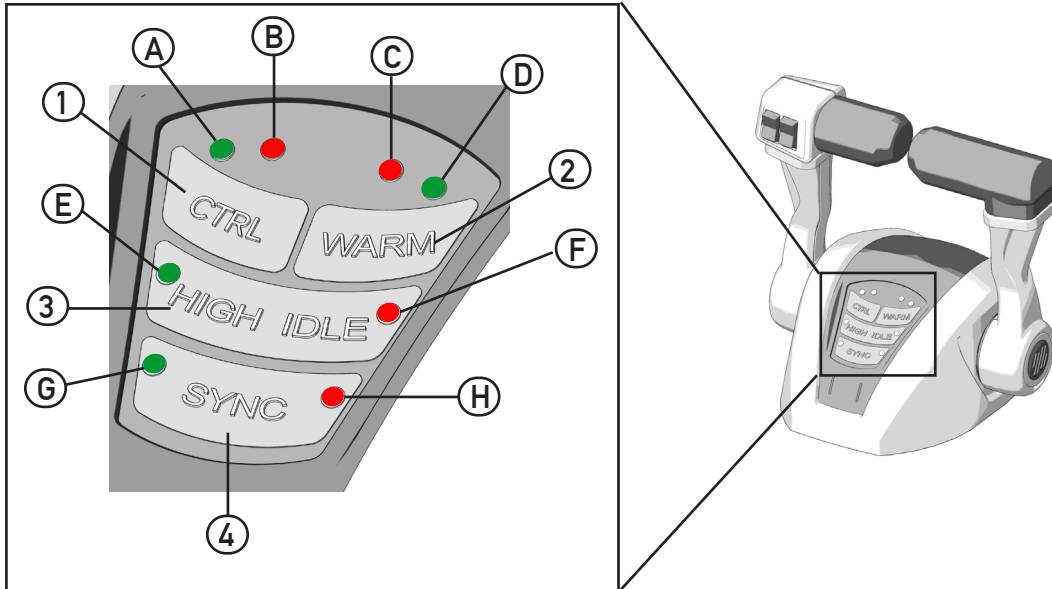

4 keys and 8 LED indicators are located on the user interface.

Item	Description	Function
1	Key CTRL	Enabling and disabling of the control station
2	Key WARM	Enabling and disabling of throttle mode in neutral position
3	Key HIGH IDLE	Enabling and disabling of the high idle and alarm silencing
4	Key SYNC	Enabling and disabling of the engine revolution synchronizing and docking modes
A	GREEN LED	Enabling of the port station or single-engine
B	RED LED	Enabling of the throttle mode in neutral position for the port engine (or single-engine). Failure signalling referring to the port engine (or single-engine)
C	RED LED	Enabling of the throttle mode in neutral position for the starboard engine. Failure signalling referring to starboard engine
D	GREEN LED	Starboard station enabled
E	GREEN LED	Troll mode enabled
F	RED LED	High idle mode enabled
G	GREEN LED	Sync mode enabled
H	RED LED	Docking mode enabled

The control station is provided with a buzzer signalling the operating condition and possible failures.

## SAIL VERSION

An enlargement of the user interface on the control stations is shown in the following figure.

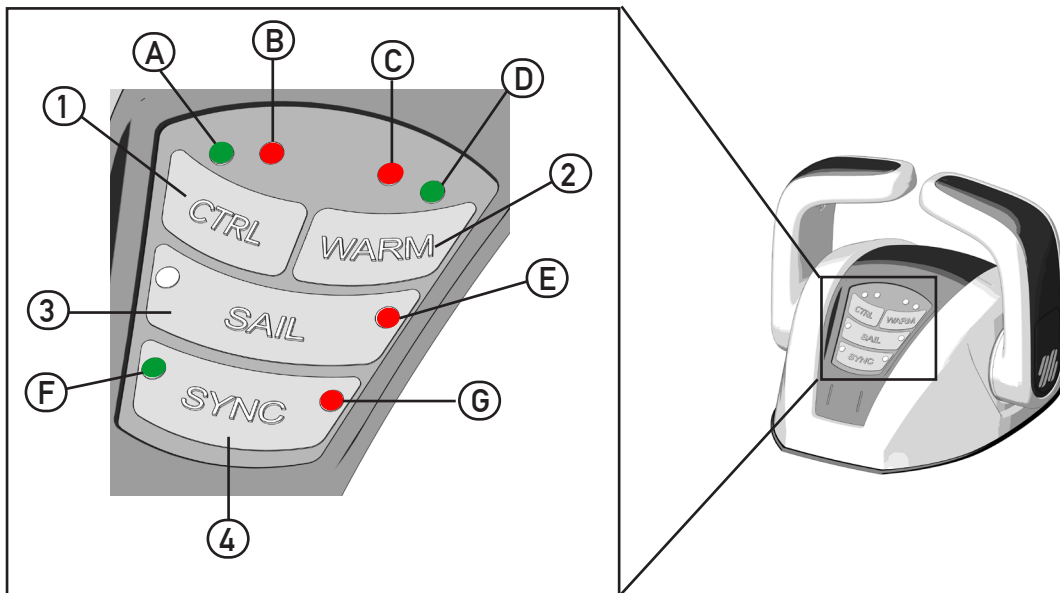

4 keys and 8 LED indicators are located on the user interface.

Item	Description	Function
1	Key CTRL	Enabling and disabling of the control station
2	Key WARM	Enabling and disabling of throttle mode in neutral position
3	Key SAIL	Enabling and disabling of the Sail mode*
4	Key SYNC	Enabling and disabling of the engine revolution synchronizing and docking modes
A	GREEN LED	Enabling of the port station or single-engine
B	RED LED	Enabling of the throttle mode in neutral position for the port engine (or single-engine). Failure signalling referring to the port engine (or single-engine)
C	RED LED	Enabling of the throttle mode in neutral position for the starboard engine. Failure signalling referring to starboard engine
D	GREEN LED	Starboard station enabled
E	RED LED	Sail mode* enabled
F	GREEN LED	Sync mode enabled
G	RED LED	Docking mode enabled

The control station is provided with a buzzer signalling the operating condition and possible failures.

\*The SAIL function is designed for sail boats: this function provides comfort when sailing, reducing friction and not stressing the axle holding systems.

ENGLISH

The sail boat (if fitted with engines with steerable propeller blades) when sailing needs the engine blades to be oriented in closing with the reverse gear engaged: this is to reduce friction and not to stress the axle holding systems when sailing.

After turning off the throttle with the key, the user has the option of activating the SAIL function by commanding the actuator in reverse position: the SAIL function is activated with the ignition off. When the user switches the ignition back on, the motor propellers return to their standard position.

## 2.2 Operation of the control station levers

In case of single-engine boats, the control stations are provided with a lever (the port lever); in case of twin-engine boats, the control stations are provided with two levers: the port lever controls the port engine and the starboard lever controls the starboard engine.

The position of the levers determines the operating conditions of the engines. Each lever angle gives a proper shift position and throttle value.

In the twin-engine control station, the levers work in the same way.

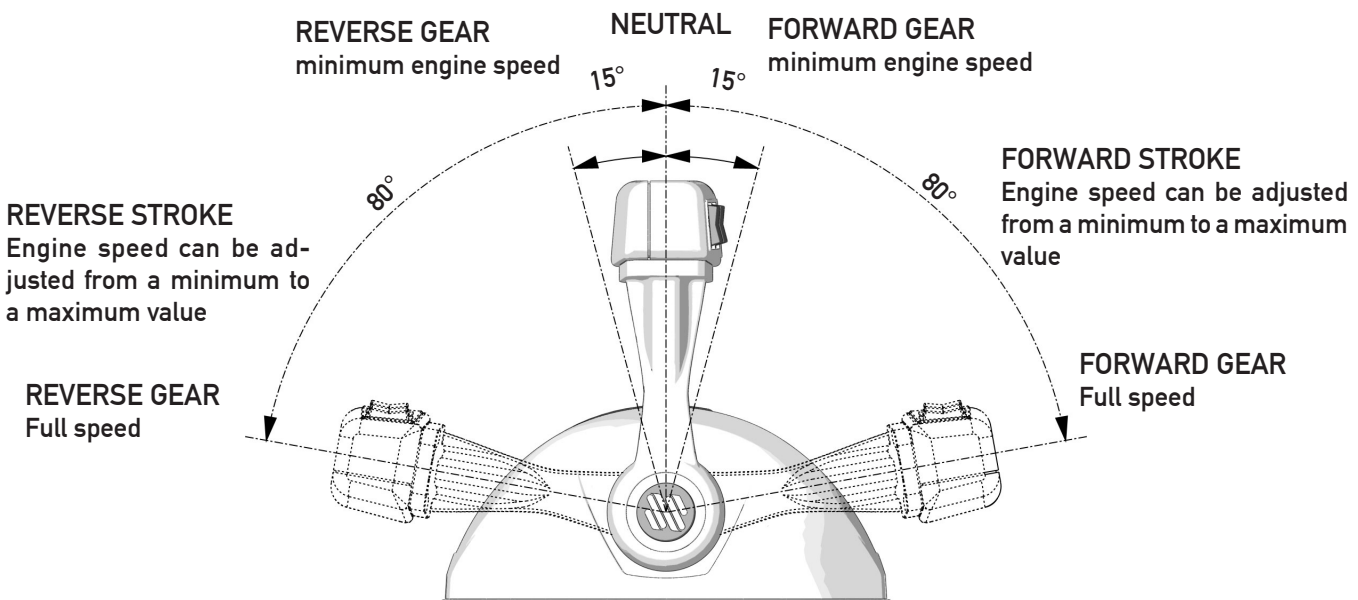

**NEUTRAL** - When the lever is in central position, the engine is in neutral and at idle.

**DETENT FORWARD** -When the lever has a forward inclination of 15° the relevant shift is enabled and puts into forward gear. The throttle remains at idle.

**DETENT REVERSE** -When the lever has a reverse inclination of 15° the relevant shift is enabled and puts into forward gear. The throttle remains at idle.

**ACCELERATION** - When the lever inclination angle is higher than 15° the engine acceleration starts. The maximum acceleration value (full speed) is obtained with a lever inclination of 80°.

The throttle detent forward and detent reverse are controlled in a similar way.

The throttle answer with respect to the lever angle can be selected by the user during calibration.

**RETURN TO NEUTRAL** - When the lever is put in the centre again, the throttle is at idle and the shift is in neutral position. The control station signals that the lever has reached the neutral position with a short sound.

## 2.3 System start

To correctly start the system, follow the steps below:

### 2.3.1 System power supply

First of all supply the system with power by means of the thermal switch located on the power cord. The switch must be set to the ON position (switch closed). If there are two power cords and, therefore, two thermal switches, make sure that both of them are set to the ON position.

### 2.3.2 Panel key enabling

The panel keys of the engine of each boat must be enabled.

When the engine panel key contact is closed (key enabled) the control station signals to the user that the boat can be controlled with a LED flashing and an intermittent sound signalling.

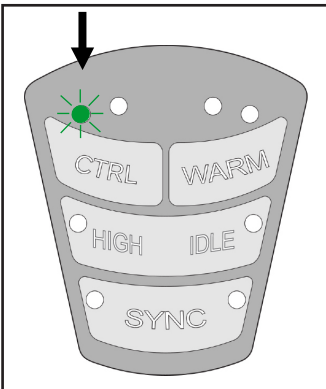

In single-engine boats, the flashing LED is the one shown in the picture aside. The same occurs in twin-engine boats, if the port engine key is enabled. During this condition the system cannot be controlled: any lever movement has no effects on the engine; therefore, pressure on trim switches is ignored.

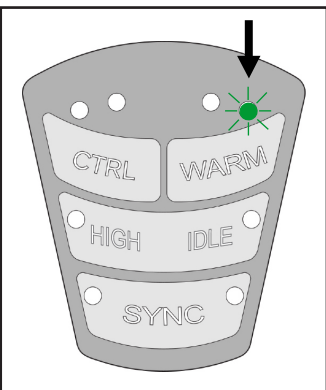

In twin-engine boats, if the starboard engine key is enabled, the flashing LED will show that the starboard station has been enabled (see picture aside). In this case too, the system cannot be controlled.

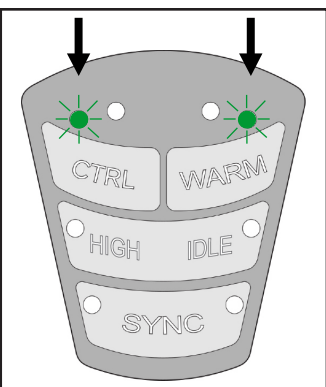

In twin-engine boats, when both engine keys are enabled, both LEDs will flash showing that the station has been enabled, as shown in the picture aside. In this case too, the system cannot be controlled.

If the engine key is disabled and the control is waiting for the station enabling, the relevant LED will switch off showing that the relevant side is disabled.

## 2.3.3 Engine switching on

It is possible to switch on the engines if the following conditions are met:

- 1) The lever must be set to the neutral position; a click is heard when placing the lever vertically in order to reach such a position. A mark on the control station package shows the lever neutral position.
- 2) The key must be enabled;
- 3) No failure must prevent the shift from being set to the neutral position and the throttle from being at idle. In this case a proper acoustic/visual message will warn the user and the problem will appear on the control unit display.

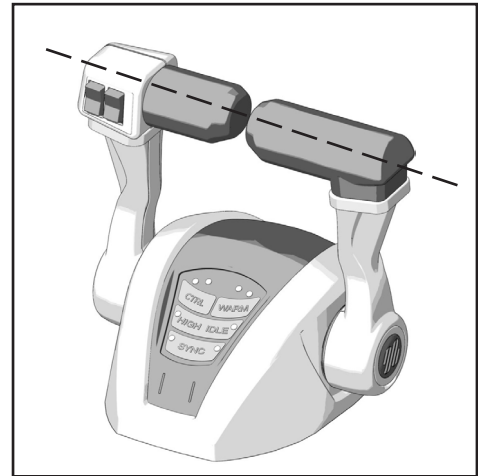

### NOTICE

The previous considerations are valid for both engines in case of twin-engine installations.

### ⚠ DANGER

The engine start inhibition is ensured only if the proper switches have been connected as indicated in the installation manual.

## 2.3.4 Control enabling

To control the system it is necessary to enable the required control station.

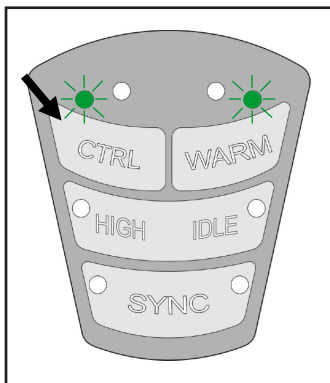

To carry out this operation, push key CTRL once if the following conditions are met:

- 1) The lever must be in neutral position.
- 2) The panel key must be enabled.
- 3) No failure must prevent the control station from operating.
- 4) The other control stations are disabled.

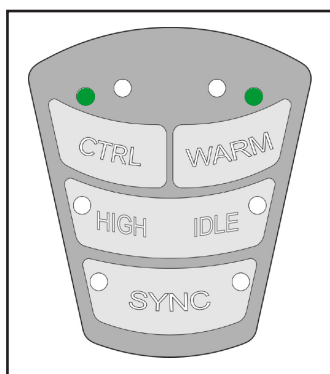

When the control station is enabled, the relevant green LED lights up and the buzzer turns off.

The control station can be partially enabled or cannot be enabled depending on the conditions described above, since they could apply to a single engine or to none of them.

If the control station is enabled partially, the green LED corresponding to the disabled part of the system will keep on blinking and the buzzer will keep on sounding.

To control the other side too, check the points described above then press key CTRL.

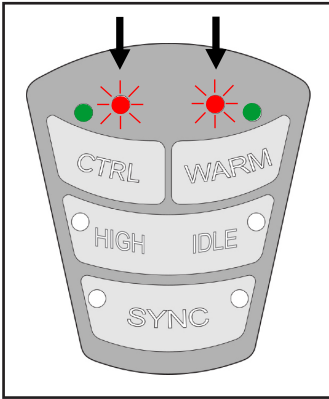

If the engine key is disabled while the station is enabled, the relevant LED will switch off indicating that that side is disabled.

If there is a failure, the control station will produce an acoustic signal and the red LEDs will blink: the left LED for the port engine (or single-engine boats) and the right one for the right engine.

Each failure has got its own alarm code with a different sound sequence.

The display on the control unit will provide the user with more information about the kind of alarm enabled.

## 2.3.5 Multiple control stations

If more control stations are installed on the boat, it is possible to use only one station at a time, therefore only one control station at a time can be enabled.

To change station, keep key CTRL pressed for a few seconds to disable the controlled station.

The station can be disabled if:

- 1) The lever is in neutral position.
- 2) No failure prevents the control station from operating.

If these conditions occur, the control station will be disabled and the enabling procedure described above can be carried out.

## 2.4 Use modes

After enabling the desired station, it is possible to put into reverse or forward gear and adjust the engine speed by moving the levers.

Similarly, if this function has been set up, the trim attitude can be modified by means of the two trim switches on the port lever.

Moreover there are some functions that modify the control normal operation: WARM-UP, AUTOSYNC, HIGH-IDLE or SAIL, DOCKING, TROLL.

### 2.4.1 WARM UP mode

This mode allows the user to vary the engine speed with the shift in neutral position.

To enable this mode the following conditions must be met:

- The station must be enabled.
- The lever must be in neutral position.
- There must be no failures that could cause problems during the enabling of this mode.

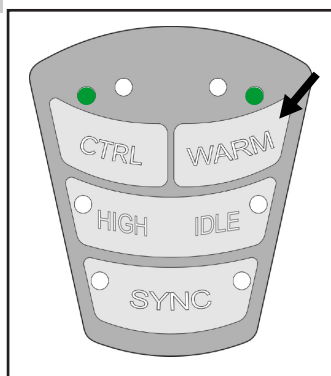

To enable the WARM-UP mode, press the proper key on the user interface.

The WARM UP red LEDs will light up when the mode is enabled.

In single-engine systems, only the left LED will light up.

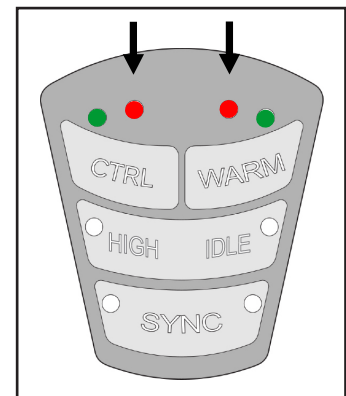

#### **⚠ WARNING**

In twin-engine systems the WARM-UP mode can be enabled only on one engine: the proper LED will indicate the engine on which this mode is enabled. In this case pay great attention not to accidentally start the engine which is not in WARM UP mode.

The WARM-UP mode turns off when the controlled station is disabled and it does not turn on when the station is enabled again.

To disable the WARM-UP mode the following conditions must be met:

- The lever must be in neutral position.
- There must be no failures that could prevent this mode from being disabled.

To disable the WARM-UP mode, press key WARM-UP. The WARM UP red LEDs switch off indicating that the mode has been disabled.

In single-engine systems, only the left LED will switch off.



**⚠ WARNING**

In twin-engine systems the WARM-UP mode can be disabled only on one engine: the proper LED will indicate the engine on which this mode is enabled.

It is possible that the WARM-UP mode is enabled only on one engine and the control station meets the conditions listed previously (levers in neutral positions, no failure): in this case, when pressing key WARM again, this mode will be disabled on the engine on which it was enabled and viceversa.

To disable the WARM-UP mode on both the engines, do as follows:

- Put the lever of the engine in WARM-UP mode to the forward position.
- Press key WARM-UP.
- Move the aforementioned lever to the neutral position.
- Press key WARM-UP again.

## 2.4.2 AUTOSYNC mode

This mode allows the automatic synchronization of the engine speed of both the boat propulsors: the starboard engine will adjust its revolutions according to the port engine.

This mode can be found on twin-engine systems only.

This mode can be enabled if at least one station is controlled regardless of the lever position by pressing key SYNC on the user interface.

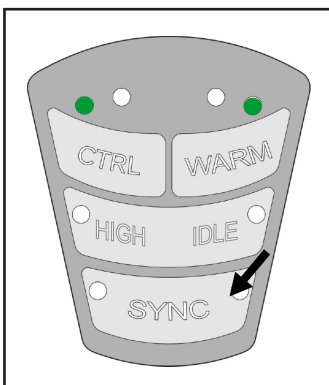

The green SYNC LED will light up without flashing indicating that this mode has been enabled.

Under this condition, the engine synchronization occurs if the following requirements are met:

- The difference in inclination between the levers is lower than 15°.
- The throttle percentage of both the engines (which is given by the levers) is higher than the 20% of the total amount.
- Both the engines are put into forward gear.

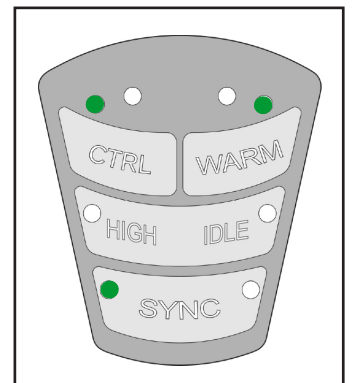

The SYNC LED will blink when the engines are synchronized.

**⚠ WARNING**

The engine synchronization is enabled only when the proper LED is blinking.

When one of the previous conditions is not met anymore, the synchronization is disabled but the SYNC mode is still on. When all the conditions are met, the synchronization can be enabled again.

The SYNC LED on the user interface lights up without blinking when the synchronization is disabled.

To disable the AUTOSYNC mode, press key SYNC: the green SYNC LED switches off.

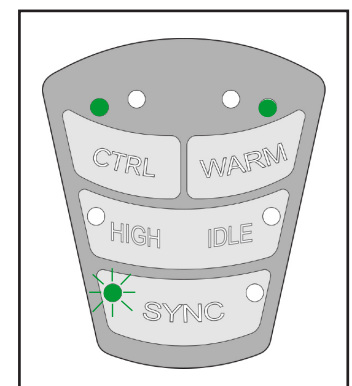

When changing the control station, the AUTOSYNC mode is disabled.

## 2.4.3 HIGH-IDLE mode

The HIGH-IDLE mode allows the user to increase the engine idle speed.

To enable this mode the following conditions must be met:

- The station must be enabled.
- The DOCKING mode must not be enabled.
- There must be no failures that could prevent this mode from being enabled.

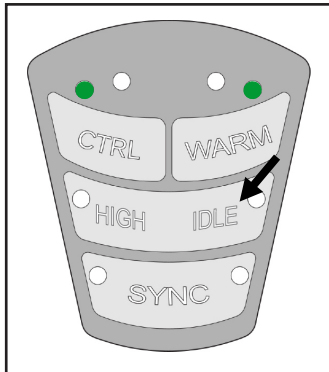

To enable the HIGH-IDLE mode just press the proper key on the user interface.

The proper red LED will light up indicating that the HIGH-IDLE mode is on.

In the engine acceleration curve the high idle value is set as the idle speed.

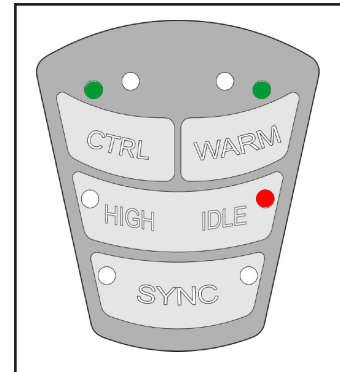

To disable the HIGH-IDLE mode, press the proper key on the user interface: the HIGH-IDLE red LED switches off when this mode is disabled.

### **⚠ WARNING**

In a twin-engine system the HIGH-IDLE mode can be enabled on one engine only. In this case the HIGH-IDLE red LED will blink.

The HIGH-IDLE mode is disabled when changing the control station.

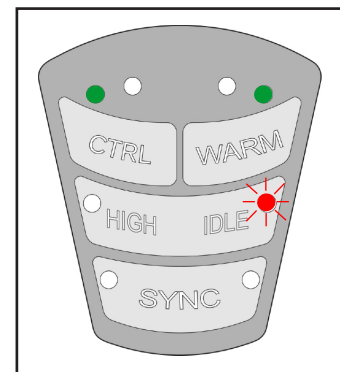

## 2.4.4 SAIL mode

The SAIL mode is designed for sail boats: this function provides comfort when sailing.

The sail boat (if fitted with engines with steerable propellers) needs the engine blades to be oriented in closing with the reverse gear engaged when sailing: this is to reduce friction and not to stress the axle holding systems. After turning off the throttle with the key, the user has the option of activating the SAIL function by commanding the actuator in reverse position: the SAIL function is activated with the ignition off.

When the user switches the ignition back on, the motor propellers automatically return to their standard position.

To enable this mode the following conditions must be met:

- The engines must be switched off but the control station must be supplied with power.
- There must be no failures that could prevent this mode from being enabled.

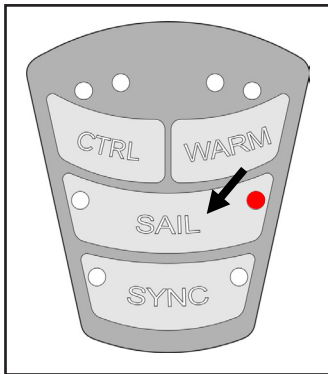

To enable the SAIL mode, just press the proper key on the user interface for three seconds.

The proper red LED will light up indicating that the SAIL mode is on.

To disable the SAIL mode, just take control of the station again after switching on the engine. The red LED switches off when this mode is disabled.

## 2.4.5 Troll mode

The TROLL mode allows the user to control the trolling-valve of each engine.

To enable this mode the following conditions must be met:

- The station must be enabled.
- All the other functions must be disabled.
- The levers must be in neutral position.
- There must be no failures that could prevent this mode from being enabled.

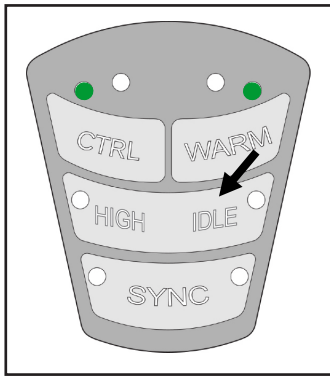

To enable the TROLL mode, keep key HIGH-IDLE pressed for a few seconds. The mode is enabled when the key is released.

The proper green LED will blink indicating that the TROLL mode is on.

To disable the TROLL mode, keep the proper key on the user interface pressed for a few seconds: the TROLL green LED will switch off.

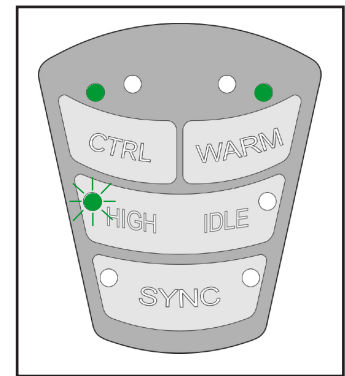

ENGLISH

### **⚠ WARNING**

In a twin-engine system, the TROLL mode cannot be enabled on one engine only.

The TROLL mode is disabled when changing the control station.

The TROLL mode is not available in the systems with SAIL mode.

## 2.4.6 Docking mode

The DOCKING mode allows the user to reduce the maximum engine speed without reducing the lever angular travel.

The DOCKING mode allows a higher sensitivity on throttle, therefore it is suitable for docking.

To enable this mode the following conditions must be met:

- The station must be enabled.
- HIGH-IDLE, SAIL and TROLL modes must be off.
- There must be no failures that could prevent this mode from being enabled.

To enable the DOCKING mode, keep key SYNC pressed; the mode will be enabled when the key is released.

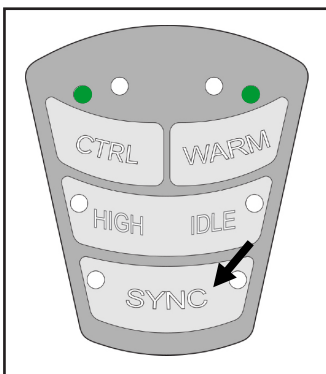

The proper red LED will light up indicating that the DOCKING mode is on.

In the engine acceleration curve, the maximum engine speed is set as half of the normal speed.

To disable the DOCKING mode, press the proper key on the user interface for a few seconds: the DOCKING red LED will switch off.

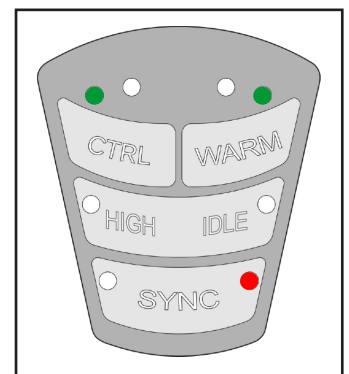

### **⚠ WARNING**

In a twin-engine system, the DOCKING mode can be enabled on one engine only. In this case the DOCKING red LED will blink.

The DOCKING mode is disabled when changing the control station.

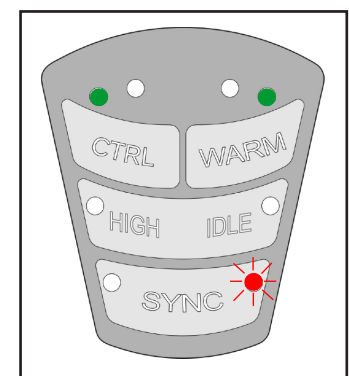

ENGLISH

## 2.4.7 Panel brightness adjustment

It is possible to increase or reduce the LED brightness on the user interface by keeping key WARM pressed for a few seconds.

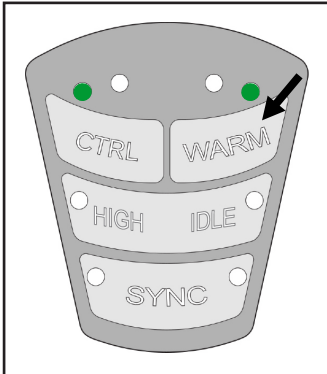

Each second the key is kept pressed, the LED brightness will increase up to the maximum value. By keeping the key pressed, the brightness will be reduced to the minimum, then increased again until the key is released.

To change the LED brightness, it is not necessary to enable the station.

The LED brightness will be changed only on the station which was controlled by means of key WARM.

The new brightness value will be maintained until the system is switched off by means of the proper thermal switch.

## 3 WARNINGS AND ALARMS

The system **Power A Mark II™** warns the operator about failures by means of the control station (visual and acoustic signals) and the control unit display.

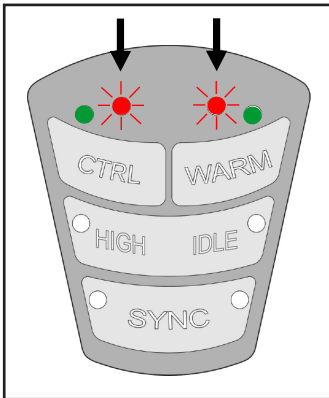

The central red LEDs on the user interface show failures.

A buzzer inside the lever produces a sound that can be stopped by keeping key HIGH IDLE (or SAIL) pressed for a few seconds.

No visual signals will be shown when an alarm is stopped.

Failures are divided into two categories: warnings (not severe failures) and errors (severe failures).

The left red LED will indicate a failure on the port engine (or on single-engine boats) and the right one for the starboard engine.

To acknowledge the failure it is necessary to read the error code on the control unit display.

The error is shown on the diagnostic main page.

In single-engine systems, if there are no errors, this page is displayed as follows:

```
N  0.0% 0.0%
```

If there is an error, indication "ER" is displayed as follows:

```
ER 0.0% 0.0%
```

In twin-engine systems, if there are no errors, this page is displayed as follows:

```
N  0.0% 0.0%
N  0.0% 0.0%
```

If there is an error, indication "ER" is displayed as follows:

```
ER 0.0% 0.0%
ER 0.0% 0.0%
```

Indication ER can be present on one side only. In this case, the error is detected on the relevant side (the first line refers to port, the second one to starboard).

For more information about the failure it is necessary to consult the item diagnostic page.

To scroll the diagnostic pages press the right arrow of the navigation switch.

To select the desired items (marked by an asterisk on its right) press key OK at the centre of the navigation switch.

The following pages show one table for each diagnostic page on the control unit that can help to acknowledge the failure.

ENGLISH

### 3.1 Control station

No.	Alarm code	Meaning	Solution
1	Miss shift msg port	The system has detected the lack of CAN message of the port shift.	Check the CAN bus connection or the power cord of the unit controlling the shift.
2	Miss acc msg port	The system has detected the lack of CAN message of the port throttle.	Check the CAN bus connection or the power cord of the unit controlling the throttle.
3	Miss disp msg port	The system has detected the lack of CAN message of the port control unit.	Check the CAN bus connection
4	Miss troll msg port	The system has detected the lack of CAN message of the port troll.	Check the CAN bus connection or the power cord of the unit controlling the trolling valve
5	Sensor fault port	The system has detected a failure on the left sensor of the control station.	Contact the technical assistance service to replace the control station
6	Miss shift msg stbd	The system has detected the lack of CAN message of the starboard shift.	Check the CAN bus connection or the power cord of the unit controlling the shift.
7	Miss acc msg stbd	The system has detected the lack of CAN message of the starboard throttle	Check the CAN bus connection or the power cord of the unit controlling the throttle.
8	Miss disp msg stbd	The system has detected the lack of CAN message of the starboard control unit.	Check the CAN bus connection
9	Miss troll msg stbd	The system has detected the lack of CAN message of the starboard troll.	Check the CAN bus connection or the power cord of the unit controlling the trolling valve
10	Sensor fault stbd	The system has detected a failure on the right sensor of the control station.	Contact the assistance service to replace the control station
11	Brownout	The system has detected a heavy brownout that could have affected the operation.	Check the electrical connections that feed the system, check the battery charge.
12	Ecc fault	Problem in the control station processor.	Contact the technical assistance service to replace the control station
13	Watchdog fault	Problem in the control station processor.	Contact the technical assistance service to replace the control station



14	PLL fault	Problem in the control station processor.	Contact the technical assistance service to replace the control station
15	Miss parameters	Problem in the control station processor.	Contact the technical assistance service to replace the control station.

### 3.2 V-throttle, I-throttle, PWM throttle, SAEJ-throttle

No.	Alarm code	Meaning	Solution
1	Miss shift msg port	The system has detected the lack of CAN message of the port shift.	Check the CAN bus connection or the power cord of the unit controlling the shift.
2	Miss disp msg port	The system has detected the lack of CAN message of the port control unit.	Check the CAN bus connection
3	Miss troll msg port	The system has detected the lack of CAN message of the port troll.	Check the CAN bus connection or the power cord of the unit controlling the trolling valve
4	Miss head msg port	The system has detected the lack of CAN message of the port control station	Check the CAN bus connection
5	Miss shift msg stbd	The system has detected the lack of CAN message of the starboard shift.	Check the CAN bus connection or the power cord of the unit controlling the shift.
6	Miss disp msg stbd	The system has detected the lack of CAN message of the starboard control unit	Check the CAN bus connection
7	Miss troll msg stbd	The system has detected the lack of CAN message of the starboard troll.	Check the CAN bus connection or the power cord of the unit controlling the trolling valve
8	Miss head msg stbd	The system has detected the lack of CAN message of the starboard control station	Check the CAN bus connection
9	Brownout	The system has detected a heavy brownout that could have affected the operation.	Check the electrical connections that feed the system, check the battery charge.
10	Ecc fault	Problem in the throttle unit processor.	Contact the technical assistance service to replace the throttle unit
11	Watchdog fault	Problem in the throttle unit processor.	Contact the technical assistance service to replace the throttle unit
12	PLL fault	Problem in the throttle unit processor.	Contact the technical assistance service to replace the throttle unit
13	Miss parameters	Problem in the throttle unit processor.	Contact the technical assistance service to replace the throttle unit

### 3.3 Shift unit

No.	Alarm code	Meaning	Solution
1	Miss acc msg port	The system has detected the lack of CAN message of the port throttle	Check the CAN bus connection or the power cord of the unit controlling the throttle.
2	Miss disp msg port	The system has detected the lack of CAN message of the port control unit.	Check the CAN bus connection
3	Miss troll msg port	The system has detected the lack of CAN message of the port troll.	Check the CAN bus connection or the power cord of the unit controlling the trolling valve
4	Miss head msg port	The system has detected the lack of CAN message of the port control station.	Check the CAN bus connection
5	Fw fbk fault port	The system has detected a problem on the forward gear solenoid valve (port or single-engine)	Check the connection reliability and the suitability of the solenoid valve.
6	Rw fbk fault port	The system has detected a problem on the reverse gear solenoid valve (port or single-engine)	Check the connection reliability and the suitability of the solenoid valve.
7	Nt fbk fault port	The system has detected a problem on the neutral solenoid valve, if it is used (port or single-engine).	Check the connection reliability and the suitability of the solenoid valve.
8	Miss acc msg stbd	The system has detected the lack of CAN message of the starboard throttle	Check the CAN bus connection or the power cord of the unit controlling the throttle.
9	Miss disp msg stbd	The system has detected the lack of CAN message of the starboard control unit.	Check the CAN bus connection
10	Miss troll msg stbd	The system has detected the lack of CAN message of the starboard troll.	Check the CAN bus connection or the power cord of the unit controlling the trolling valve
11	Miss head msg stbd	The system has detected the lack of CAN message of the starboard control station.	Check the CAN bus connection
12	Fw fbk fault stbd	The system has detected a problem on the forward gear solenoid valve (starboard)	Check the connection reliability and the suitability of the solenoid valve.
13	Rw fbk fault stbd	The system has detected a problem on the reverse gear solenoid valve (starboard)	Check the connection reliability and the suitability of the solenoid valve.

14	Nt fbk fault stbd	The system has detected a problem on the neutral solenoid valve, if it is used (starboard)	Check the connection reliability and the suitability of the solenoid valve.
15	Brownout	The system has detected a heavy brownout that could have affected the operation.	Check the electrical connections that feed the system, check the battery charge.
16	Ecc fault	Problem in the shift unit processor.	Contact the technical assistance service to replace the shift unit
17	Watchdog fault	Problem in the shift unit processor.	Contact the technical assistance service to replace the shift unit
18	PlI fault	Problem in the shift unit processor.	Contact the technical assistance service to replace the shift unit
19	Miss parameters	Problem in the shift unit processor.	Contact the technical assistance service to replace the shift unit
20	Warning underV	The system has detected a low feeding on the shift unit. Performances are not changed.	Check the battery charge

### 3.4 Mechanical actuator used as throttle

No.	Alarm code	Meaning	Solution
1	Miss shift msg	The system has detected the lack of CAN message of the shift.	Check the CAN bus connection or the power cord of the unit controlling the shift.
2	Miss disp msg	The system has detected the lack of CAN message of the control unit.	Check the CAN bus connection
3	Miss troll msg	The system has detected the lack of CAN message of the troll.	Check the CAN bus connection or the power cord of the unit controlling the trolling valve
4	Miss head msg	The system has detected the lack of CAN message of the control station.	Check the CAN bus connection
5	Sensor pos fault	The system has detected a problem on the actuator position sensor.	Contact the technical assistance service to replace the actuator
6	Sensor V fault	The system has detected a problem on the actuator power sensor.	Contact the technical assistance service to replace the actuator
7	Sensor I fault	The system has detected a problem on the actuator current sensor.	Contact the technical assistance service to replace the actuator
8	Over I fault	The system has detected an excessive current absorption of the actuator.	Check if the mechanical cable is intact and free to slide.
9	Brownout	The system has detected a heavy brownout that could have affected the operation.	Check the electrical connections that feed the system, check the battery charge.
10	Ecc fault	Problem in the control station processor.	Contact the technical assistance service to replace the control station
11	Watchdog fault	Problem in the control station processor.	Contact the technical assistance service to replace the control station
12	PLL fault	Problem in the control station processor.	Contact the technical assistance service to replace the control station
13	Miss parameters	Problem in the control station processor.	Contact the technical assistance service to replace the control station

14	PWM off	The system has turned off the actuator as a precaution after a heavy brownout.	Check the electrical connections that feed the system, check the battery charge. Then turn off and on the system by means of the thermal switches
15	Warning underV	The system has detected a low feeding on the mechanical actuator. Performances are not changed.	Check the battery charge.
16	Warning position	The system has detected that the actuator shaft is placed at more than 1.5 mm from the desired position (target).	Check if the mechanical cable is free to slide and if there is excessive clearance

### 3.5 Mechanical actuator used as shift

No.	Alarm code	Meaning	Solution
1	Miss acc msg	The system has detected the lack of CAN message of the throttle.	Check the CAN bus connection or the power cord of the unit controlling the throttle.
2	Miss disp msg	The system has detected the lack of CAN message of the control unit.	Check the CAN bus connection
3	Miss troll msg	The system has detected the lack of CAN message of the troll.	Check the CAN bus connection or the power cord of the unit controlling the trolling valve
4	Miss head msg	The system has detected the lack of CAN message of the control station.	Check the CAN bus connection
5	Sensor pos fault	The system has detected a problem on the actuator position sensor.	Contact the technical assistance service to replace the actuator
6	Sensor V fault	The system has detected a problem on the actuator power sensor.	Contact the technical assistance service to replace the actuator
7	Sensor I fault	The system has detected a problem on the actuator current sensor.	Contact the technical assistance service to replace the actuator
8	Over I fault	The system has detected an exceeding current absorption of the actuator.	Check if the mechanical cable is intact and free to slide.
9	Brownout	The system has detected a heavy brownout that could have affected the operation.	Check the electrical connections that feed the system, check the battery charge.
10	Ecc fault	Problem in the control station processor.	Contact the technical assistance service to replace the control station
11	Watchdog fault	Problem in the control station processor.	Contact the technical assistance service to replace the control station
12	PLL fault	Problem in the control station processor.	Contact the technical assistance service to replace the control station
13	Miss parameters	Problem in the control station processor.	Contact the technical assistance service to replace the control station

14	PWM off	The system has turned off the actuator for precaution after a heavy brownout.	Check the electrical connections that feed the system, check the battery charge. Then turn off and on the system by means of the thermal switches
15	Warning underV	The system has detected a low power on the mechanical actuator. Performances are not changed.	Check the battery charge.
16	Warning fw position	The system has detected that the actuator shaft is placed at more than 1.5 mm from the desired position (target) for the forward gear.	Check if the mechanical cable is free to slide and if there is excessive clearance
17	Warning rw position	The system has detected that the actuator shaft is placed at more than 1.5 mm from the desired position (target) for the reverse gear.	Check if the mechanical cable is free to slide and if there is excessive clearance
18	Warning neutral position	The system has detected that the actuator shaft is placed at more than 1.5 mm from the desired position (target) for the neutral position.	Check if the mechanical cable is free to slide and if there is excessive clearance



## 3.6 Control unit

No.	Alarm code	Meaning	Solution
1	Miss shift msg port	The system has detected the lack of CAN message of the port shift.	Check the CAN bus connection or the power cord of the unit controlling the shift.
2	Miss acc msg port	The system has detected the lack of CAN message of the port throttle.	Check the CAN bus connection or the power cord of the unit controlling the throttle.
3	Miss troll msg port	The system has detected the lack of CAN message of the port troll.	Check the CAN bus connection or the power cord of the unit controlling the trolling valve
4	Miss head msg port	The system has detected the lack of CAN message of the control station (port or single-engine)	Check the CAN bus connection
5	Miss shift msg stbd	The system has detected the lack of CAN message of the starboard shift.	Check the CAN bus connection or the power cord of the unit controlling the shift.
6	Miss acc msg stbd	The system has detected the lack of CAN message of the starboard throttle	Check the CAN bus connection or the power cord of the unit controlling the throttle.
7	Miss troll msg stbd	The system has detected the lack of CAN message of the starboard troll.	Check the CAN bus connection or the power cord of the unit controlling the trolling valve
8	Miss head msg stbd	The system has detected the lack of CAN message of the starboard control station	Check the CAN bus connection
9	Brownout	The system has detected a heavy brownout that could have affected the operation.	Check the electrical connections that feed the system, check the battery charge.
10	Ecc fault	Problem on the control unit processor.	Contact the technical assistance service to replace the control unit
11	Watchdog fault	Problem on the control unit processor.	Contact the technical assistance service to replace the control unit.
12	PLL fault	Problem on the control unit processor.	Contact the technical assistance service to replace the control unit

13	Wrong software ver	The system has detected a problem of incompatibility among the different software versions of the components.	Contact the technical assistance service to replace the unsuitable components.
14	Miss parameters	Problem on the control unit processor.	Contact the technical assistance service to replace the control unit

## 4 SAFETY WARNINGS

This section shows the safety rules which must be followed for the correct equipment operation. We recommend reading this section and the other manuals supplied with the steering system components carefully.

### 4.1 Safety standards during installation and use

RESPECT STRICTLY the following safety rules:

**ULTRAFLEX** declines all responsibility in case the user does not follow these rules and it is not responsible for negligence during the use of the system.

#### DANGER

- DO NOT PUT HANDS BETWEEN THE MOVING PARTS.
- Do not disable the safety devices.
- Do not modify or add devices to the system, without **ULTRAFLEX** written authorisation or technical intervention which will prove the modification.
- Do not use the equipment for a purpose different from the one it has been designed for, which is specified in the installation and maintenance manual.
- Do not let non-specialized staff perform the installation.

#### WARNING

- When the system is installed, clean thoroughly to prevent foreign bodies from entering it. Even the smallest object could damage the system permanently.
- Avoid contact between cables and heat sources.

### 4.2 Clothing

#### WARNING

During installation, inspection or maintenance, IT IS STRICTLY FORBIDDEN to wear necklaces, bracelets or clothes which could get caught in the moving parts.

## 5 MAINTENANCE

### 5.1 Routine maintenance

The routine maintenance consists in a series of periodical checks and actions to keep the product in optimum operating condition thus avoiding that the external environment may jeopardize its operation and safety.

#### **⚠ WARNING**

If the maintenance checks are not carried out, Poor maintenance may result in loss of steering and cause property damage and/or personal injury.

#### 5.1.1 Cleaning

Ordinary cleaning ensures good operation and optimum product aesthetics.

Only the control station and the control unit need to be washed.

We recommend using no aggressive products that might damage the metal parts or the external plastic parts of the control station.

After using the boat, wash the exposed control stations with fresh water.

The display glass and the navigation switch located on the control unit must be kept clean by using a wet cloth.

#### 5.1.2 One month after product installation

The routine maintenance for the first month includes:

- Check of the mechanical actuator calibration;
- Check of the mechanical actuator carriage tightening;
- Greasing (by using a marine lubrication) of the mechanical actuator stems;
- Cleaning operations.

#### 5.1.3 Every three months

Every three months the following operations are required:

- Check of the mechanical actuator calibrations;
- Check of the mechanical actuator carriage tightening;
- Greasing (by using a marine lubrication) of the mechanical actuator stems;
- Cleaning operations.

#### 5.1.4 Every year

Every year:

- Check possible damages or deterioration on the mechanical cables of the mechanical actuators.

#### **NOTICE**

Every three year, replace the split pin of the mechanical actuator.

- Check of possible damages or deterioration on the electric cable of the system.
- Check of the correct insertion and/or tightening of all connectors located on the system.  
When checking the electric cables, make sure that the interconnections have not been damaged while handling them.  
Check that the ground connections have no surface oxidation. In that case, we recommend using sprays or common products to protect and preserve the electric contacts.
- Check of the components fastening the system.
- Check the absence of corrosion or damage on the system components.
- Check of the functions by means of the tests described in paragraph 7.2 of the Installation manual.

### 5.2 Extraordinary maintenance

#### Technical Assistance

For any information or for assistance with unusual applications, please contact our Technical Assistance Service (See paragraph "Informative letter").

## 6 DISMANTLING

### 6.1 Dismantling

When for any reason, the system is put out of service, it is necessary to follow some rules in order to respect the environment.

Sheaths, pipelines, plastic or non-metallic components must be disassembled and disposed of separately.

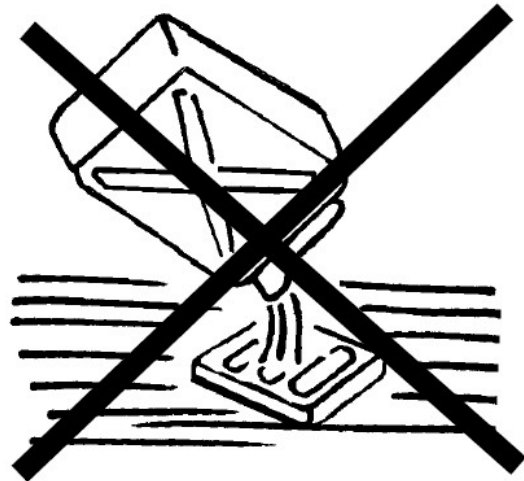

# ENCLOSURES

Cable compatibility:

MerCruiser stern drive cable: use the 2 bushes provided to adapt it to the locking system.

C2, C7, C8 and MACHZero cables, use the adaptors included in each actuator.

Mounting of adapters on cables:

MerCruiser stern drive cable: insert the two pressure bushes on the cable cylinder, mount the cable on the locking system according to the procedure described in paragraph 6.4 of the Installation manual.

C2, C7, C8 and MACHZero cables: follow the instructions described in paragraph 6.4 mount the cable on the locking system according to the procedure described in paragraph 6.4. of the Installation manual.